

GALAXIA

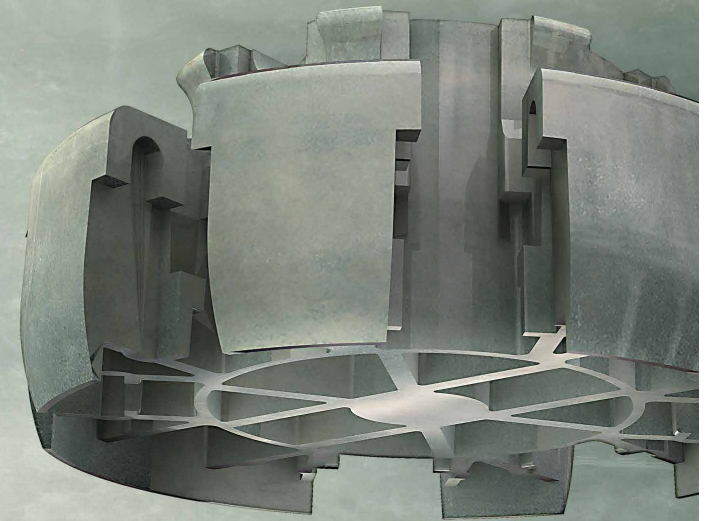





I

Abbiamo ideato un nuovo futuro per vivere lo spazio esterno dominato da sinergia tra:

- Tecnologia
- Ergonomia
- Design
- Innovazione

La sapienza e l'eccellenza italiana artigiana si sono evolute e raffinate attraverso studi accurati e dedicati, tecnologici e di ingegneria, ottenendo risultati STRATOSFERICI: GALAXY.

UK

We have created a new future to live the outdoor dominated by:

- Technology
- Ergonomics
- Design
- Innovation

The wisdom and the artisan Italian excellence have evolved and refined through accurate and dedicated studies, technological and engineering, obtaining stratospheric results: GALAXY.

D

Wir haben eine neue Zukunft geschafft um das Outdoor zu leben, beherrscht von der Synergie zwischen:

- Technologie
- Ergonomie
- Design
- Innovation

Die Weisheit und die handwerkliche italienische Exzellenz haben sich weiterentwickelt und verfeinert durch genaue, relevante, technologische und technische Forschungen, und somit stratosphärische Ergebnisse erzielt: GALAXY.

F

Nous avons créé un nouveau produit reposant sur un nouveau concept , la synergie entre :

- Technologie
- Ergonomie
- Conception
- Innovation

L'excellence et le raffinement de l'artisanat italien ont évolué grâce à des études précises et des avancées technologiques de l'ingénierie , permettant d'obtenir des résultats exceptionnels: GALAXY.

E

Hemos ideado un nuevo futuro para vivir el espacio exterior en sinergia dominado entre:

- Tecnología
- Ergonomía
- Diseño
- Innovación

La sabiduría y la excelencia italiana artesana se han evolucionado y perfeccionado a través de estudios cuidadosos y dedicados, tecnológicos y de ingeniería, obteniendo resultados ESTRATOSFÉRICOS: GALAXY

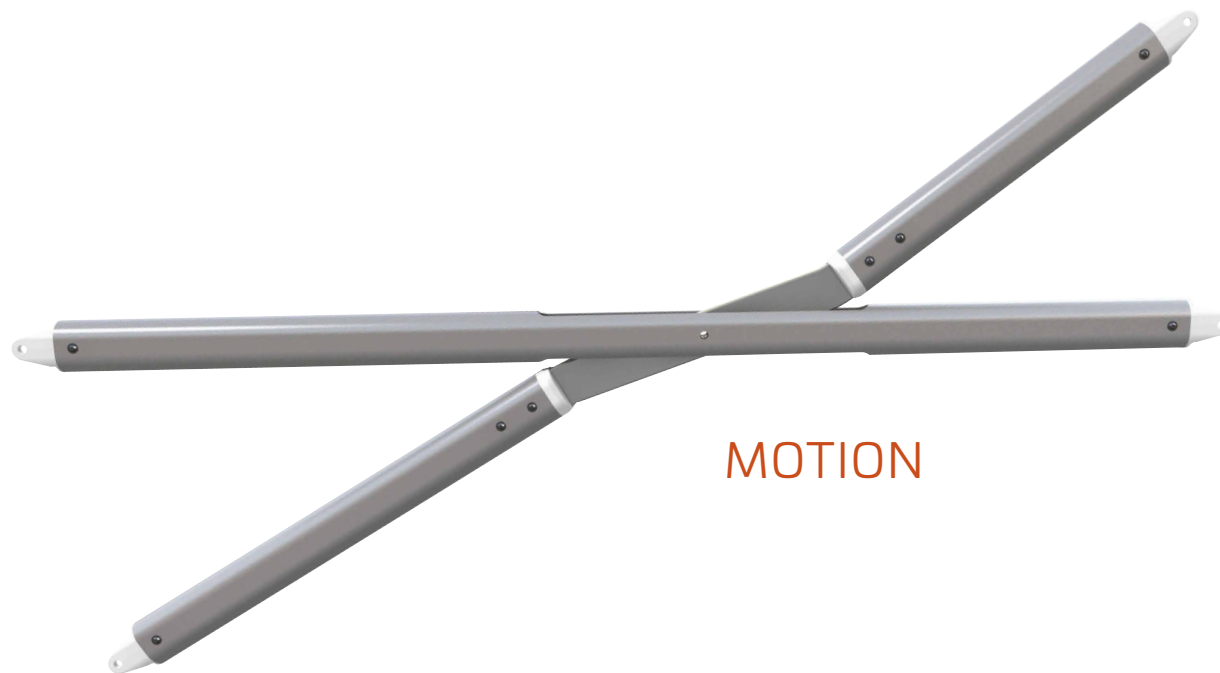

I

SISTEMA "MOTION"

Alla base del funzionamento innovativo c'è il Sistema Motion, che evolve il concetto di apertura e chiusura retrattile dell'ombrellone. In questa applicazione innovativa i bracci a forbice azionano direttamente le corone centrali per l'apertura e la chiusura.

UK

SYSTEM "MOTION"

At the base of the innovative operation there is the Motion system, which evolves the concept of opening and closing the sunshade retractable. In this innovative application arms scissor directly drive the central crowns for opening and closing.

D

SYSTEM "MOTION"

An der Basis des innovativen Betriebs befindet sich das System Motion, dass das Konzept der Öffnung und Schließung des einziehbaren Schirmes entwickelt. In dieser innovativen Anwendung setzen die scherenfoermige Arme direkt die zentralen Kronen zum Öffnen und Schließen in Bewegung.

F

SYSTEM "MOTION"

A la base de l'opération novatrice il y a le système Motion, qui évolue le concept d'ouverture et de fermeture du parasol rétractable. Dans cette innovante les bras à ciseaux operant directement sur les couronnes centrales pour l'ouverture et la fermeture.

E

SISTEMA "MOTION"

A la base de la operación innovadora está el sistema de movimiento, que evoluciona el concepto de abrir y cerrar el parasol retráctil. En esta aplicación innovadora, los brazos de tijeras conducen directamente las coronas centrales por apertura y cierre.



LIFT ACTION



ERGONOMY DESIGN



I

LIFT ACTION

La principale innovazione è l'applicazione di una molla a gas che agisce sul sistema MOTION assistendo l'apertura e riducendo al minimo lo sforzo in fase di apertura e chiusura dell'ombrellone.

ERGONOMY DESIGN

Non solo tecnologia e funzionalità, ma anche ergonomia nei movimenti. Il design e il gusto italiano incidono sapientemente e rendono questo ombrellone unico in ogni singola linea trasmettendo sensazioni di equilibrio nelle forme.

UK

LIFT ACTION

The main innovation is the application of a gas spring which acts on the motion system by assisting the opening and minimizing the effort in opening and closing of the umbrella.

ERGONOMY DESIGN

Not only technology and functionality, but also ergonomics of movement. The design and Italian style influence wisely and make this unique umbrella in every single line transmitting feelings of balance in the forms.

D

LIFT ACTION

Die wichtigste Neuerung ist die Anwendung einer Gasfeder, die auf das System Motion wirkt und eine mühelose Öffnung und Schließung des Schirmes ermöglicht.

ERGONOMY DESIGN

Nicht nur Technik und Funktionalität, sondern auch Ergonomie der Bewegung. Das Design und das italienische Stil haben einen grossen Einfluss und machen aus diesem Schirm ein einzigartiges Produkt. Jede einzelne Linie uebermittelt Gleichgewicht.

F

LIFT ACTION

La principale innovation est la présence d'un ressort à gaz agissant sur le fonctionnement du parasol en facilitant l'ouverture et en réduisant l'effort d'ouverture et de fermeture du parasol.

ERGONOMY DESIGN

Non seulement la technologie et la fonctionnalité, mais aussi l'ergonomie du mouvement. La conception et l'influence de style italien à bon escient et de faire ce parasol unique dans chaque ligne, transmettant des sentiments d'équilibre dans les formes.

E

LIFT ACTION

La principal innovación es la aplicación de un muelle de gas que actúa sobre el sistema de movimiento por ayudar a la apertura y reducir al mínimo el esfuerzo en la apertura y cierre del parasol.

ERGONOMY DESIGN

No sólo la tecnología y funcionalidad, sino también ergonomía de movimiento. El diseño y la influencia de estilo italiano inciden sabiamente y hacen este parasol único en cada línea, transmitiendo la sensación de equilibrio en las formas.





FRAME

I

- TECNOLOGIA
- ERGONOMIA
- DESIGN
- INNOVAZIONE

... abbiamo raggiunto livelli altissimi di innovazione del prodotto.

UK

- TECHNOLOGY
- ERGONOMICS
- DESIGN
- INNOVATION

... we reached very high levels of product innovation.

F

- TECHNOLOGY
- ERGONOMICS
- DESIGN
- INNOVATION

... nous avons atteint des niveaux très élevés de l'innovation produit.

D

- TECHNOLOGIE
- ERGONOMIE
- DESIGN
- INNOVATION

... Wir haben sehr hohe Innovationsniveaus erreicht.

E

- TECNOLOGÍA
- ERGONOMÍA
- DISEÑO
- INNOVACIÓN

... hemos alcanzado niveles muy altos de innovación en este productos.





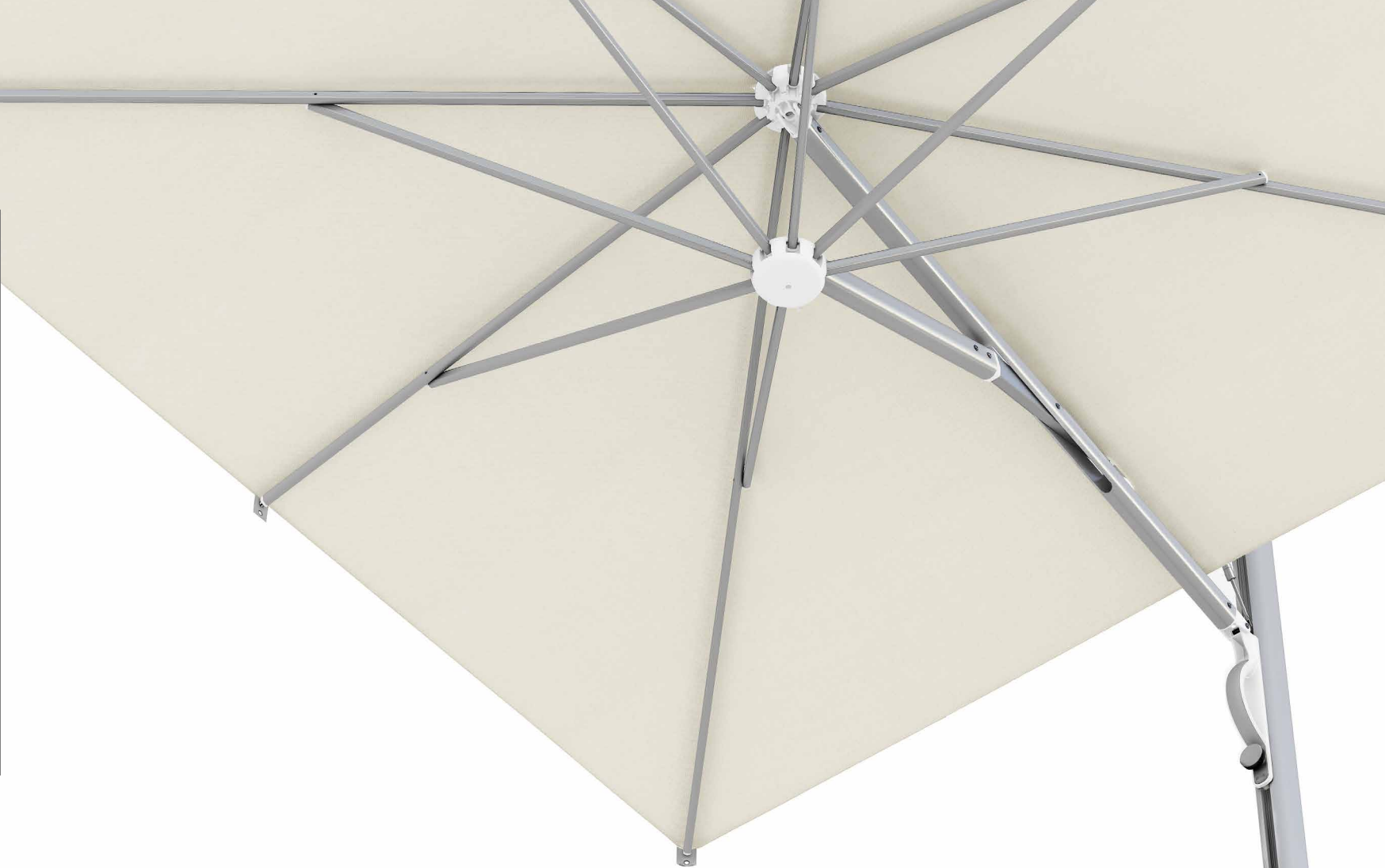

Astro Spacegrey

I

Prodotto futuristico, adatto per ambienti moderni e minimalisti. Telaio con finitura effetto SpaceGrey.

UK

Futuristic product, suitable for modern and minimalist environments. Frame finish Space Grey effect.

D

Futuristisches Produkt, geeignet für moderne und minimalistische Milieus. Gestell mit Spacegrau Effekt.

F

Produit futuriste, adapté aux environnements modernes et minimalistes. Finition structure d'effet Space Grey.

E

Producto futurista, adecuado para ambientes modernos y minimalistas. Estructura acabada efecto SpaceGrey.





Astro Carbon

I

Connubio tra il futuro e il classico.
Armonico per tutti gli ambienti.
Telaio con effetto graffite
metallizzato, unico nel suo genere.

UK

Marriage between the future and
the classic. Harmonious for all
environments.
Frame with unique metallic
graphite effect.

D

Verbindung zwischen Zukunft
und Klassiker. Harmonisch für alle
Milieus.
Gestell mit einzigartigem Metallic-
Graphit Effekt.

F

Mariage entre l'avenir et le
classique. Harmonieux pour tous
les environnements.
Armature avec effet métallique de
graphite, produit unique.

E

Connubio entre el futuro y el
clásico. Armonioso para todos los
ambientes.
Marco con efecto de grafito
metálico, único en su género.

Tech specs

Astro Spacegrey / Carbon

		CHARACTERISTICS								FINISHING						OPTIONAL	
↑	COD	KG	M ³	Icon 1	Icon 2	Icon 3	Icon 4	Icon 5	Icon 6	Icon 7	Icon 8	Icon 9	Icon 10	Icon 11	Icon 12	Icon 13	
3,0x3,0	CARBON C3030 ASC SPACEGREY C3030 ASS	45	0,40	110x76	CARBON SPACEGREY	8	CARBON SPACEGREY	18x30	●	●	●	●	●	●	●	●	●

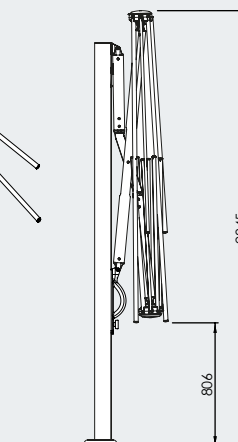
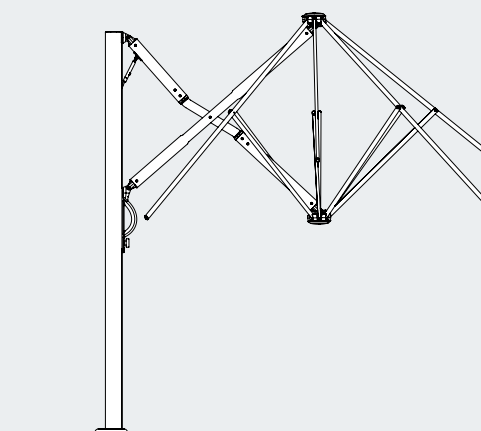
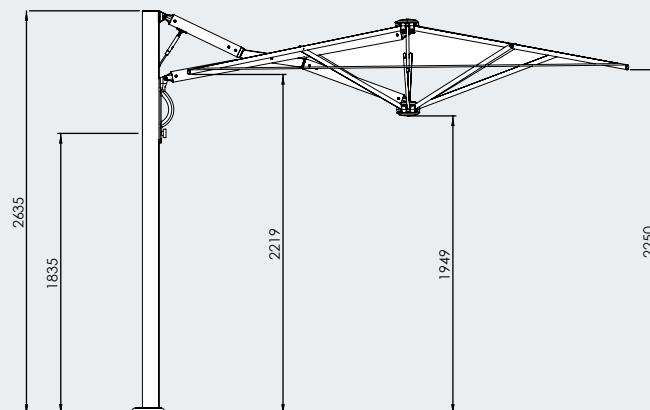
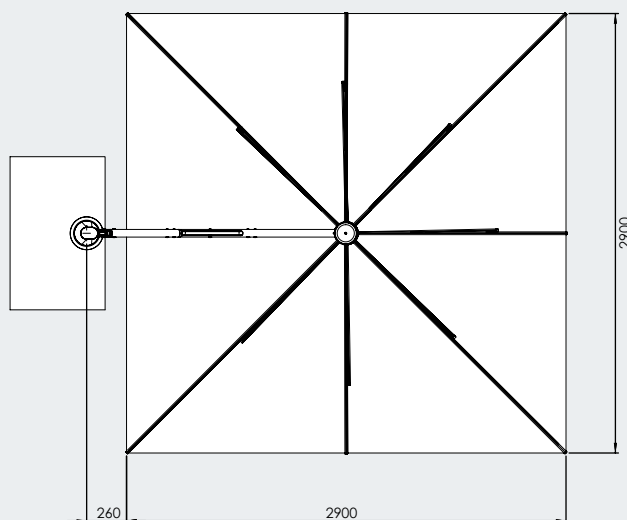

I
MOTION è una soluzione retrattile che permette di aprire o chiudere l'ombrellone vicino al palo, senza rimuovere tavoli e sedie. La combinazione tra MOTION ed ACTION System permette di aprire o chiudere l'ombrellone in una sola operazione. Grazie alla molla a gas, che compensa il peso del ombrello, il trattamento è molto leggero. Telaio in alluminio disponibile in versione anodizzato SpaceGrey o verniciato a polveri Carbon. Componenti e viteria in acciaio inox. Accessori in Nylon ABS.

UK
The MOTION is a retractable solution and permits to open or close the parasol near to the pole without removing table and chairs. The combination of MOTION and ACTION System allows to open or close the parasol in one operation. Thanks to the gas spring, which compensates the weight of the umbrella, the handling is very light. Aluminium frame available in anodized version SpaceGrey or Carbon coated. Components and stainless steel hardware. Accessories Nylon ABS.

D
MOTION ist eine einziehbare Lösung und erlaubt, den Sonnenschirm am Mast zu öffnen oder zu schließen, ohne Tisch und Stühle umzuräumen. Die Kombination von MOTION und ACTION System ermöglicht das Öffnen oder Schließen des Sonnenschirms in einem Arbeitsgang. Dank der Gasfeder, die das Gewicht des Schirmes ausgleicht, ist die Handhabung sehr leicht. Gestell aus Aluminium in eloxierter Ausführung oder pulverbeschichtet Farbe SpaceGrey erhältlich. Bestandteile und Schrauben aus Edelstahl. Zubehör aus ABS Nylon.

F
Le système MOTION est une solution rétractable et permet d'ouvrir ou de refermer le parasol sur le mât, sans enlever les tables et les chaises. La combinaison du MOTION et du système ACTION permet d'ouvrir ou de fermer le parasol en une seule opération. Grâce au ressort à gaz, qui compense le poids du parasol, la manipulation est très légère. Armature disponible en version anodisé Space Grey avec peinture en poudre couleur Carbon. Composants et matériel en acier inoxydable. Accessoires Nylon ABS.

E
The MOTION es una solución retráctil que permite abrir y cerrar el parasol acerca del poste sin quitar mesas y sillas. La combinación entre MOTION y ACTION System permite abrir o cerrar el parasol en una única operación. Gracias al muelle de gas, que compensa el peso de la sombrilla, el trato es muy ligero. Marco de aluminio disponible en la versión anodizado SpaceGrey o pintado en polvo Carbon. Componentes y herrajes de acero inoxidable. Accesorios en Nylon ABS.

Bases

OPTIONAL



N°4 BC5151
N°12 BC5050

N°2 BV5050

FISSAGGIO TERRA
INGROUND FIX



BC 5151G



BV5050G



BV5050B

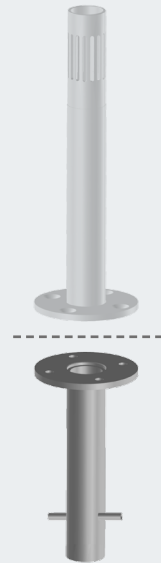

BTA



500X500 mm
500X500 mm
500x500 mm
500x500 mm

COD

BC 5151
BC 5151G
BV5050G
BV5050B



110 mm
110 mm
270 mm
270 mm

KG

60 kg
60 kg
80 kg
80 kg

Fabric collection



350 gr/m²
ACRYLIC

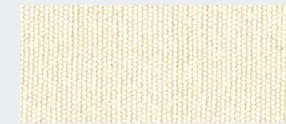

A1N
ECRU

70/80% 20/30% 85/89% >250 mm

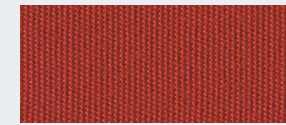

T2N
TERRACOTTA

> 90% < 10% 100% >250 mm

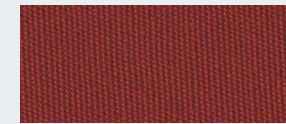

T3N
BORDEAUX

> 90% < 10% 100% >250 mm

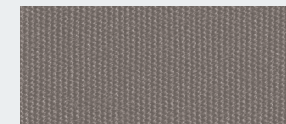

T6N
TAUPE

> 90% < 10% 100% >250 mm

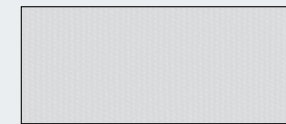

T7N
WHITE

70/80% 20/30% 85/89% >250 mm

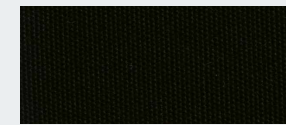

S1N
BLACK

> 90% < 10% 100% >250 mm

Materiali e finiture Materials and finishing

Componenti e profili alluminio Aluminium components and profiles



SPACEGREY

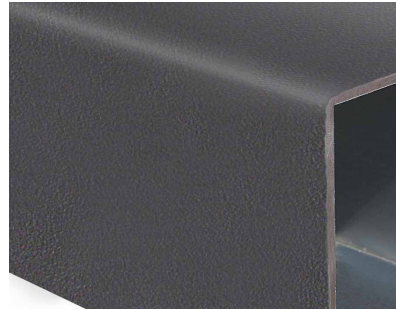

CARBON

Profili Stecche Ribs Profiles



SPACEGREY



CARBON





.Dimensione (metri)
.Dimensions (meters)
.Masse (Meter)
.Dimensions (metres)
.Dimensiones (en metros)



.Codice
.Code
.Artikelcode
.Code
.Código



.Lunghezza
.Length
.Laenge
.Longueur
.Longitud



.Peso
.Weight
.Gewicht
.Poids
.Peso



.Volume (m3)
.Volume (m3)
.Volumen (m3)
.Volume (m3)
.Volumen (m3)



.Stecche
.Ribs
.Streben
.Baleines
.Varillas



.Apertura con molla a gas
.Gas spring opening
.Gasfeder oeffnung
.Ouverture avec ressort à gaz
.Abertura muelle a gas



.Con base/supporto
.With base/support
.Mit Staender/Huelse
.Avec base/support
.Con base/ soporte

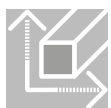

.Sezione stecche
.Rib section
.Strebenprofil
.Section baleines
.Sección varillas



.Camino antivento
.Wind cap
.Windfang
.Souffle
.Chimenea antiviento



.Fodero
.Cover bag
.Schutzhuelle
.Housse
.Forro



.Sistema retrattile
.Retractable system
.Einziehbares System
.Système retractile
.Sistema retráctil



.Base girevole a 360°C
.Revolving base 360°C
.360°C drehbarer Staender
.Base tournant 360°C
.Base giratoria 360º



.Sezione sostegno (mm)
.Support section (mm)
.Mastprofil (mm)
.Section support (mm)
.Sección soporte (mm)



.Viteria in inox e ottone nichelato
.Screws in Stainless steel and nickel plated brass
.Edelstahlschrauben und vernickeltes Messing
.Visserie inox et laiton nickelé
.Tornillos en acero inoxidable y bronce niquelado



.Tipo finitura della struttura/sostegno/componenti
.Finishing for frame/structure/components
.Ausfuehrung des Gestells/der Struktur/der Bestandteile
.Finition armature/structure/composants
.Tipo de acabado de la estructura/Soportes/componente



.Colore dei componenti/stecche
.Component/Ribs colour
.Farbe der Bestandteile und Streben
.Couleur des composants et baleines
.Color de los componentes ò piezas/Varillas ò listones



.Stecca con sistema "easy change"
.Ribs with "easy change" system
.Streben mit "easy change" System
.Baleines avec "easy change" système
.Varillas con sistema de " cambio fácil"



.Massima Stabilità Ottenibile
.Maximum Obtainable Stability
.Maximal Erhaeltliche Stabilitaet
.Maximum De Stabilité Realisable
.Maxima Estabilidad Posible



.Peso consigliato in condizioni normali
.Recommended weight in normal condition
.Empfohlenes gewicht unter normalen bedingungen
.Poids recommande dans des conditions normales
.Peso recomendado en condiciones normales



.Peso minimo richiesto
.Minimum ballast required
.Erforderliches mindestgewicht
.Poids minimum requis
.Peso minimo requerido



SCOLARO Mario & Fabio srl
Via Liguria, 197
35040 Casale di Scodosia (PD)
ITALY

T. +39 0429 656687
F. +39 0429 657874

info@scolaro-parasol.it
www.scolaro-parasol.it



SCOLARO-PARASOL.IT